

Eliminate the Expense of Dedicated Phone Lines!

The **FAXJ-1000** is a versatile phone/data/fax switch with the ability to automatically route calls via fax CNG tone, central office distinctive ringing, or touch tones included in the dial string by the calling party. In addition, the **FAXJ-1000** offers full manual transfer capabilities.

The **FAXJ-1000** stores and retransmits caller ID information so that it is truly caller ID compatible.



www.VikingElectronics.com
Information: 715-386-8861

Features

- Four ports allow any four analog devices to share a single line
- **Routes calls via CNG tone, distinctive ringing, touch tones sent by calling device or manually**
- Provides realistic ring-back tones while re-ringing selected device
- **Transfer incoming calls from one port to another as often as may be required during the same call**
- **Caller ID information is stored and retransmitted during transfer**
- Automatic "privacy" eliminates interruptions on both in and outbound calls
- Monitors for calling party control (CPC)
- All in and outbound calls are routed to the phone 1 port during a power failure
- Manual mode will not interfere with C.O. provided voice mail
- **Ports are balanced to prevent noise on long runs**
- **Compatible with high-speed modems**
- **Surge protection on both power and phone line**
- **Internal Call Mode**

Applications

Fax Machines

- Retail
- Commercial
- Industrial
- Governmental
- Home office

Modem Terminals

- Personal computers
- Vending machines
- Remote access applications

Point-Of-Sale Terminals

- Fast food chains
- Convenience stores
- Retail stores

Specifications

Power: 120V AC/13.8V AC 1.25A, UL listed adapter provided

Dimensions: 133mm x 91mm x 44mm (5.25" x 3.6" x 1.75")

Shipping Weight: 1.36 kg (3 lbs)

Environmental: 0°C to 32°C (32°F to 90°F)

Humidity: 5% to 95% noncondensing

CNG Detection: 1100 Hz burst

Maximum Data Speed: 56 Kbps

Minimum CPC Time: 320ms

Ring Output: 4 REN, capable of ringing (8) 0.5 REN phones

REN: 0.7A

Connections: (1) 11-position cage clamp terminal strip

Installation

IMPORTANT: Electronic devices are susceptible to lightning and power station electrical surges from both the AC outlet and the telephone line. It is recommended that a surge protector be installed and an earth ground connected to terminal 0 to protect against such surges.

A. Fax / Data / Phone Application

Note: The polarity of the connection to the **CO Line In** terminals shown below should be (+) or Tip to terminal 1 and (-) or Ring to terminal 2. Observing this polarity helps prevent clicks and dings of connected phones on hang up.

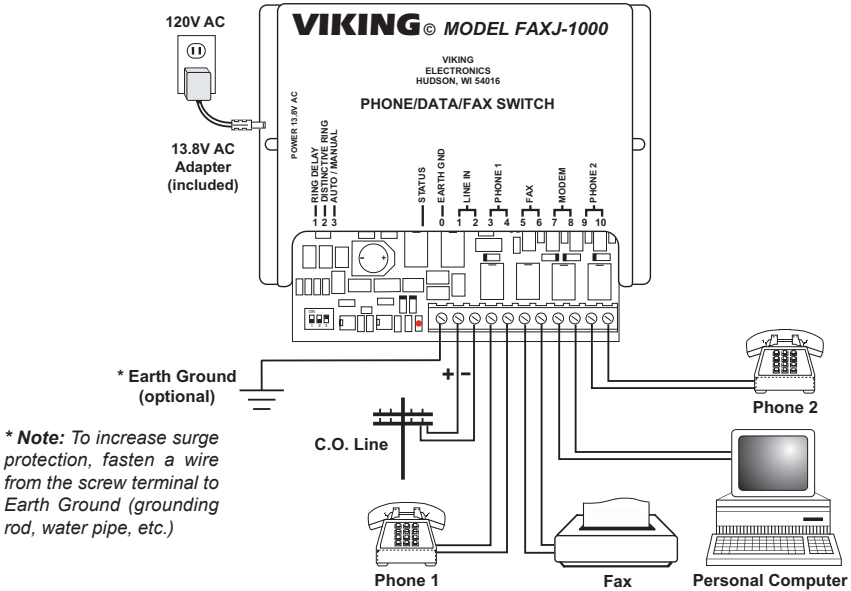

B. PABX / KSU Application

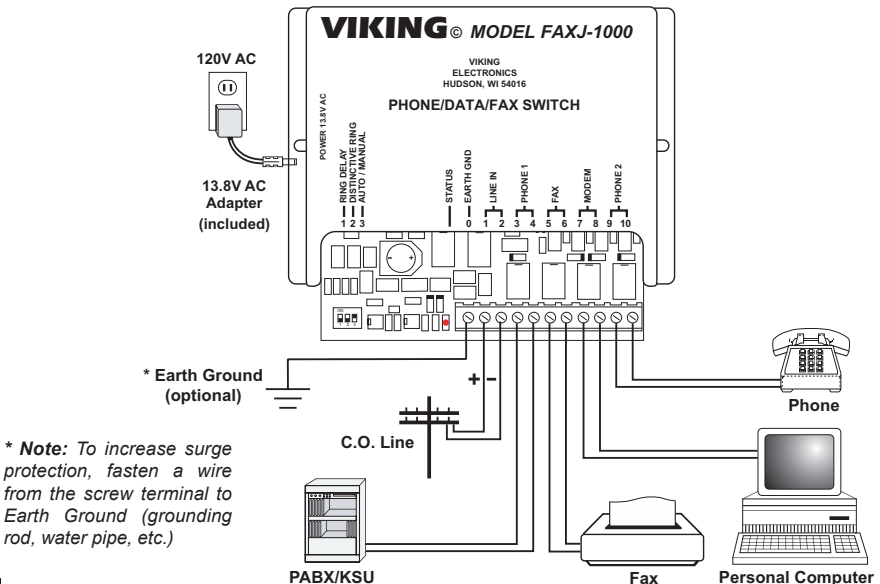

C. Installing a FAXJ-1000 on a Residential Line

The FAXJ-1000 is designed to be wired at the Demarcation Point (the point where the phone line comes into the house), but in some cases this may not be possible or convenient. This section shows a way of hooking up the FAXJ-1000 to any existing phone jack, provided the house is wired for at least two lines. A splitter/adaptor is required for each jack in the house (ie: Radio Shack part # 279-402).

Step 1	The connection of the FAXJ-1000 to the telephone line can be at any extension wall jack. Unplug anything connected to the selected jack and plug a splitter/adaptor into the jack.
Step 2	Connect the LINE IN terminals of the FAXJ-1000 to the Line 1 port of the splitter/adaptor. If the phone line is a DSL line, a DSL filter should be installed as shown in the diagram below.
Step 3	Connect the PHONE 1 terminals of the FAXJ-1000 to the Line 2 port of the splitter/adaptor.
Step 4	Unplug any phones at extension wall jacks located away from the FAXJ-1000 and plug in splitter/adapters. Reconnect the phones to the Line 2 side of the splitter/adapters.

Note: At any point "down line" from the FAXJ-1000 where it is impractical to insert a splitter/adaptor (ie: a wall mount phone), this type of jack can be converted by:

1. Swapping the GREEN wire with the BLACK wire.
2. Swapping the RED wire with the YELLOW wire.

The phone can then be plugged into the converted jack.

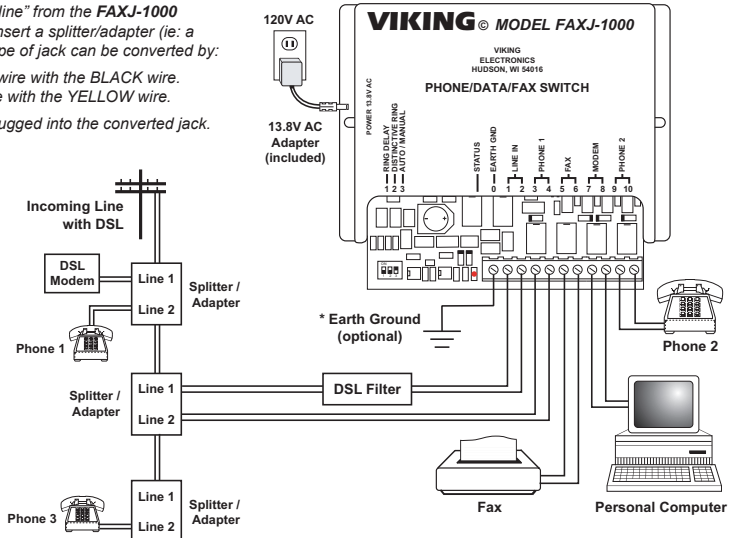

Programming

A. DIP Switch Programming

DIP Switch	Position	Description
1	OFF	Ring Limit: 5 rings (factory setting)
1	ON	Ring Limit: 10 rings
2	OFF	Distinctive Ring OFF (factory setting)
2	ON	Distinctive Ring ON
3	OFF	Automatic Answer (factory setting)
3	ON	Manual Answer

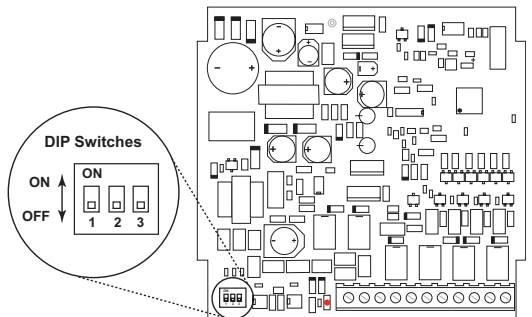

B. Accessing the Programming Mode

1. Accessing the Programming Mode Locally

Step 1	Go off-hook on any of the device ports: PHONE 1, FAX, MODEM or PHONE 2 .
Step 2	Enter * followed by the security code, (Factory 845464).
Step 3	Telephone company busy signal, reorder tone or intercept message will be heard along with a double beep to indicate you have accessed the programming mode.
Step 4	You can now Touch Tone program the features listed in section C (ignore busy signals, reorder tones or intercept messages heard while programming).
Step 5	When finished programming, hang up.

Note: If * plus an invalid security code is dialed, three error beeps will be heard. You may then dial * plus another security code to attempt access to the programming mode.

2. Accessing the Programming Mode Remotely

Step 1	Call into the FAXJ-1000 from a Touch Tone phone.
Step 2	Answer the ringing line using the phone (or device) connected to any of the device ports (this may take a few moments if the FAXJ-1000 is in the Automatic Answer mode).
Step 3	Enter * followed by the security code (Factory 845464).
Step 4	A double beep will indicate that you have accessed the programming mode.
Step 5	You can now Touch Tone program the features listed in section C .
Step 6	When finished programming, hang up.

Note: Programming from a cell-phone may not be suitable in areas with weak coverage.

*Note: If * plus an invalid security code is dialed, three error beeps will be heard. You may then dial * plus another security code to attempt access to the programming mode.*

C. Quick Programming Features

Description	Enter Digits
Enable Caller ID (factory setting)	*1
Disable Caller ID	*2
Enable CNG detection (factory setting)	*3
Disable CNG detection	*4
Normal call processing (see Operation section A)	*5
Fast call processing (see Operation section A) (factory setting)	*6
Normal outgoing call mode (factory setting)	*7
Internal call mode (see Operation section E)	*8
Reset all programming to factory default settings	###
Security Code (Factory 845464)	6 digits #47

*Note: After making an entry, two beeps indicate the entry was correct and accepted into the **FAXJ-1000**'s memory. Three beeps indicate an incorrect entry that was not accepted.*

D. Factory Reset

Remove power from the unit and make sure it is connected to a phone line. Come off hook with a phone connected to the Phone 1 port. Power up the unit and the Status LED will start to flash. After about three seconds, the LED will turn off. Hang up the phone within two seconds. The unit will perform a factory reset followed by two flashes of the LED.

Operation

A. Automatic Answer Mode

*Note: If using distinctive ring service from the telephone company and distinctive ring is enabled (dip switch 2 set to **ON**), see **Operation**, section **F** and **G**.*

If caller ID is enabled, the **FAXJ-1000** waits two seconds after the first CO (telephone company) ring to receive and store the caller ID data and then answers the line. If caller ID is disabled, it answers the line immediately after the first ring. The **FAXJ-1000** then starts generating ringback tones to the caller every four seconds, while listening in the interval between ringbacks for fax CNG tones or Touch Tones to route the call (see **Operation**, section **D** for a description of how incoming touch tones can be used to route calls). If fax CNG tone or touch tones are detected, the **FAXJ-1000** starts ringing the appropriate device, maintaining four seconds of off time between rings. If fax CNG tones or touch tones are not detected after one ringback, the **FAXJ-1000** starts ringing the Phone 1 port. The selected port is rung until the ring limit is met (see **Operation**, section **F**).

Step 1	Incoming phone line rings. If caller ID is enabled, the FAXJ-1000 delays for 2 seconds to capture and store the caller ID data.
Step 2	The FAXJ-1000 answers the line. The FAXJ-1000 is compatible with distinctive ringing features offered by the telephone company. If you have the distinctive ring feature, the FAXJ-1000 will direct the call to the appropriate port based on the ring cadence it detects (see Operation , section G).
Step 3	The FAXJ-1000 listens for one of the following: <ul style="list-style-type: none"> a. CNG tones (1100 hz tone burst) from an incoming automatic fax machine wishing to be connected to the on-premise fax machine. b. Touch tones from an incoming caller wishing to be connected to a specified device (i.e. "11111" for the Fax port, "22222" for the Modem port, "33333" for the Phone 1 port and "44444" for the Phone 2 port). c. Two touch tones from an incoming caller, a touch tone "#" and a second touch tone to route the call (ie: #1 for the Fax port, #2 for the Modem port, #3 for the Phone 1 port or #4 for the Phone 2 port). When CNG or touch tones are detected, the FAXJ-1000 generates ringing (routes the incoming call) to the appropriate port based on what was detected.
Step 4	The FAXJ-1000 generates ringback tones to the incoming caller. In the following example the caller hears one CO ring back plus two FAXJ-1000 ringback tones (before getting answered by the called device).
Step 5	If CNG tones or touch tones are not detected during any of the monitor periods, the FAXJ-1000 generates ringing (routes the incoming call) to the Phone 1 port.

1. Automatic Answer Mode Incoming Call Sequence, Caller ID Enabled and Fast call processing

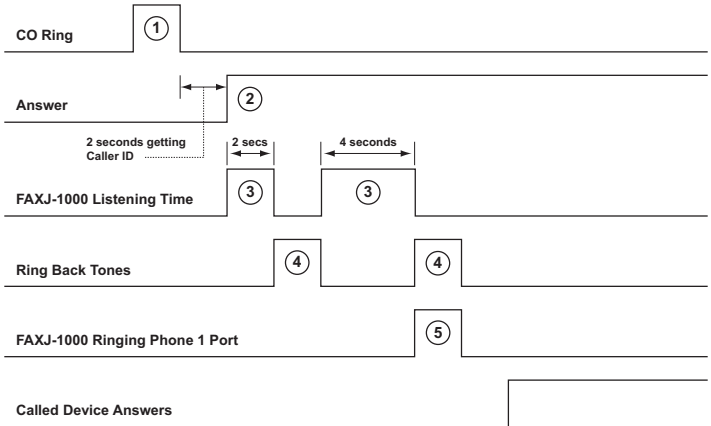

Note: If Normal call processing is enabled (see Programming section C), the FAXJ-1000 will monitor for CNG or touch tones during two 4 second periods instead of only one. If calls intended for the Fax are being incorrectly routed to the Phone 1 port (because the CNG was not detected), enable the Normal call processing mode (*5). The Normal call processing mode will cause voice callers to hear one more ringback before they ring through to the Phone 1 port.

2. Automatic Answer Mode Incoming Call Sequence, Caller ID Disabled and Fast call processing

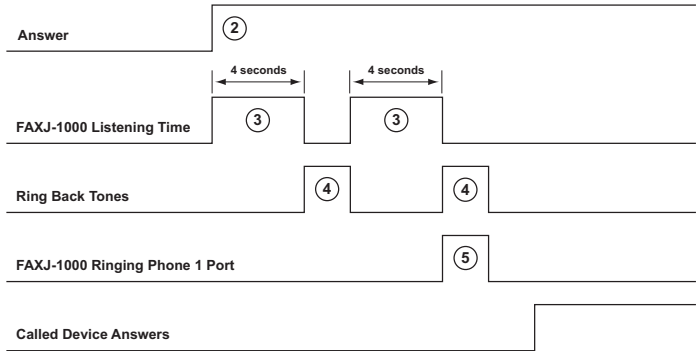

B. Manual Answer Mode

Note: If using distinctive ring service from the telephone company and distinctive ring is enabled (dip switch 2 set to ON), see Operation, section G.

In the manual answer mode, CO ringing passes directly through to the Phone 1 port. In this mode, the FAXJ-1000 waits for the call to be manually answered by the Phone 1 port and then begins watching for fax CNG tones or a touch tone transfer command to route the call. The Phone 1 port will continue to ring, subject to the Ring Limit (see Operation, section F). If the call is answered by the Phone 1 port and a fax CNG tone is detected, the FAXJ-1000 provides a busy signal to Phone 1 and starts ringing the call to the FAX port. If the call is answered by the Phone 1 port and a touch tone transfer command (see Operation section C) is detected (from either phone), the FAXJ-1000 provides a busy signal to Phone 1 and starts ringing the call to the appropriate port.

C. Transfers

While the FAXJ-1000 is a four-port unit, only one port can be connected to the phone line at any given time. If, for example, the Phone 1 port is using the line and any of the other ports tries to make a call, they are given an internally-generated busy signal. However, the FAXJ-1000 has the ability to transfer incoming calls from one port to another.

Incoming calls can be transferred by dialing "#" + the number associated with the port you want to transfer the call to. An outgoing phone call made by one of the device ports can not be transferred to another port. The FAXJ-1000 will ignore the transfer commands during outgoing calls.

When a transfer command is detected, the transferring port is provided with a busy signal and the FAXJ-1000 starts ringing the port that the call is being transferred to. It keeps track of the port that initiated the transfer so it can ring that port back if the called port doesn't answer. Any FAXJ-1000 port that is connected to the phone line can transfer an incoming call and there is no limit to the number of transfers on a given call.

Note: If a phone is wired on the CO LINE IN side of the FAXJ-1000 and you want to stop the FAXJ-1000 from transferring, pick up the phone and dial #7 between the ringbacks. The FAXJ-1000 will then hang-up and you will have the call.

Touch Tone	Port
#1	Fax
#2	Modem
#3	Phone 1
#4	Phone 2

D. Touch Tone Routing

In the automatic answer mode, the **FAXJ-1000** looks for touch tones as one method of routing the call to the correct device. These touch tones are dialed from the calling end, most often by an automatic device like a modem. In this example, the **REMOTE** modem dials the phone number of the **FAXJ-1000**, and then executes a series of pauses long enough to allow the call to connect (the **CO** to produce one ring and the **FAXJ-1000** to answer). After the **FAXJ-1000** answers, the modem dials a series of touch tone "2's" to signal that the call should be sent to the modem port (the **FAXJ-1000** needs to detect at least three touch tones to consider the string a valid command). When the **FAXJ-1000** detects the series of "2's" has ended, it then starts ringing the modem port. The chart to the right shows the port numbering.

Touch Tone	Port
1-1-1	Fax
2-2-2	Modem
3-3-3	Phone 1
4-4-4	Phone 2

It is also possible for the person calling the **FAXJ-1000** to route themselves to one of four **FAXJ-1000** devices by dialing a "*" plus a touch tone 1-4 after the **FAXJ-1000** has answered and while the **FAXJ-1000** is listening for CNG tone. "#1" steers the call to the Fax port, "#2" to the Modem port, "#3" to the Phone 1 port and "#4" to the Phone 2 port.

E. Internal Calls

When the internal call mode is enabled, this gives you the ability to create an "internal" call from one port of the **FAXJ-1000** to any other port. This allows the phones behind the **FAXJ-1000** to selectively call any phone on another port and communicate with that phone. When the two ports are connected together, the telephone line is disconnected so you don't hear busy signals, re-order tones or intercept messages while talking. It works like this:

When you go off hook on one of the ports, you are connected to dial tone from the telephone line. You then dial "#1" through "#4" to ring another port ("#1" = Fax, "#2" = Modem, "#3" = Phone 1 and "#4" = Phone 2). When the "#1" through "#4" is dialed, the telephone line is disconnected and you begin to hear a simulated ringback tone (2 seconds on, 4 seconds off), as the **FAXJ-1000** sends ringing to the appropriate port. Interrupted ringing is provided to the appropriate port until the call is answered or the port that originated the call hangs up (no limit to the number of rings). When the other port answers the call, the two ports are connected together and can communicate. Once both phones hang up, the **FAXJ-1000** returns to idle.

For more details see DOD 882.

F. Ring Limit and Rollover

Ring Limit: 5 Rings (DIP switch 1 set to off):

An incoming call with no CNG or touch tone routing will ring the Phone 1 port 5 times, if no answer the Fax port rings 5 times and if no answer the **FAXJ-1000** hangs up. When CNG tone is detected, the Fax port rings 5 times, if no answer the Phone 1 port rings 5 times and if no answer the **FAXJ-1000** hangs up. When touch tone routing is detected, the call rings the appropriate port 5 times and if no answer the **FAXJ-1000** hangs up. A transferred call rings the destination port 5 times, if no answer the call rings back to the port that transferred the call 5 times and if no answer the **FAXJ-1000** hangs up. If distinctive ring is enabled (DIP switch 2 on), the call rings the appropriate port 5 times and if no answer the **FAXJ-1000** hangs up.

Ring Limit: 10 Rings (DIP switch 1 set to on):

When DIP switch 1 is set to on, the ring limit for the Phone 1 and Phone 2 ports change from 5 to 10 rings when a call is ringing those ports or a call transferred by one of those ports is recalling because of ring no answer. All other ring limit and rollover is handled as described above, except the case of an incoming call with no CNG/touch tone routing or the "normal" ring cadence when distinctive ring is enabled. The handling of these calls depends on the mode selected:

Auto mode – the call rings to the Phone 1 port for 10 rings and if no answer the **FAXJ-1000** hangs up.

Manual mode – the call rings to the Phone 1 port indefinitely with no limit to the number of rings (the **FAXJ-1000** never answers the call).

G. Distinctive Ringing

Distinctive ringing is an option provided by some telephone companies which permits extremely accurate routing of calls. When using this feature, you are issued several telephone numbers while having only one actual telephone line. When dialed, each number will ring "distinctively". The **FAXJ-1000** can differentiate a distinctive ring cadence from a standard ring cadence and route the call accordingly. "Normal" ring cadences are routed to the Phone 1 port while distinctive ringing is routed to the other ports.

In some distinctive ring applications, calls should be routed by the distinctive ring pattern only and the **FAXJ-1000** should not transfer an answered call to the Fax port when a CNG is detected. The CNG detection feature can be disabled for these applications. To disable CNG detection, access the program mode of the **FAXJ-1000** and program "*"4".

Note: If your "normal" ring is less than 1.8 seconds or a double ring, etc., you cannot use this feature.

When the distinctive ring option is enabled in the **FAXJ-1000**, the automatic and manual answer modes can still be selected. The manual answer mode (dip switch 3 set to on) should be used in either of these cases –

- If telephone company provided voice mail is used on the same line as the **FAXJ-1000**. In the manual answer mode, the **FAXJ-1000** does not answer the "normal" ring patterns, allowing compatibility with the telephone company provided voice mail.
- If calls in the normal ring pattern should ring directly to the phone 1 port without any monitor periods for touch tones or CNG tones.

If there is no telephone company provided voice mail on the line and you prefer to monitor calls in the normal ring pattern for CNG tones or touch tones, the automatic answer mode should be used (dip switch 3 set to off).

1. Automatic Answer Mode

In the automatic answer mode, the **FAXJ-1000** monitors the ring pattern of the first CO (telephone company) ring. If the **FAXJ-1000** detects a distinctive ring pattern, it answers the call and starts ringing the device specified by the distinctive ring pattern. The selected port is rung until the ring limit is met (see **Operation**, section **F**). If the **FAXJ-1000** detects a "normal" ring pattern, it answers the call then starts generating ringback tones to the caller every four seconds, while listening in the interval in between ringbacks for fax CNG tones (if enabled) or touch tones to route the call (see **Operation**, section **D** for a description of how touch tones can be used to route calls). If fax CNG tones or touch tones are detected, the **FAXJ-1000** starts ringing the appropriate device, maintaining four seconds of off time between rings. If fax CNG tones or touch tones are not detected after one ringback, the **FAXJ-1000** starts ringing the Phone 1 port. If the call is answered by the Phone 1 port and a fax CNG tone is detected (and CNG detection is enabled), the **FAXJ-1000** provides a busy signal to Phone 1 and starts ringing the call to the Fax port. If the call is answered by the Phone 1 port and a touch tone transfer command is detected (see **Operation**, section **C**), the **FAXJ-1000** provides a busy signal to Phone 1 and starts ringing the call to the appropriate port.

2. Manual Answer Mode

In the manual answer mode, the **FAXJ-1000** monitors the ring pattern of the first CO (telephone company) ring. If the **FAXJ-1000** detects a distinctive ring pattern, it answers the call and starts ringing the port specified by the distinctive ring pattern. How the **FAXJ-1000** handles a call when the "normal" ring pattern is detected depends on the 5 or 10 ring delay selection:

- When set to a 5 ring delay (dip switch 1 set to off), the **FAXJ-1000** answers the call when a "normal" ring pattern is detected and starts ringing the Phone 1 port. If the call to the Phone 1 port is not answered after 5 rings, the **FAXJ-1000** hangs up.
- When set to a 10 ring delay (dip switch 1 set to on), the **FAXJ-1000** does not answer the call but sends ring to the Phone 1 port and regenerates caller ID after the first ring if enabled. The **FAXJ-1000** continues to send interrupted ringing to the Phone 1 port while the telephone line continues to ring, with no limit to the number of rings.

The **FAXJ-1000** waits for the call to be manually answered by the Phone 1 port and then begins listening for CNG tones (if CNG detection is enabled) or touch tone transfer commands to route the call. If the call is answered by the Phone 1 port and a fax CNG tone is detected (and CNG detection is enabled), the **FAXJ-1000** provides a busy signal to Phone 1 and starts ringing the call to the Fax port. If the call is answered by the Phone 1 port and a touch tone transfer command is detected (see **Operation**, section **C**), the **FAXJ-1000** provides a busy signal to Phone 1 and starts ringing the call to the appropriate port.

The drawings show the ring cadences and the **FAXJ-1000** ports they correlate to:

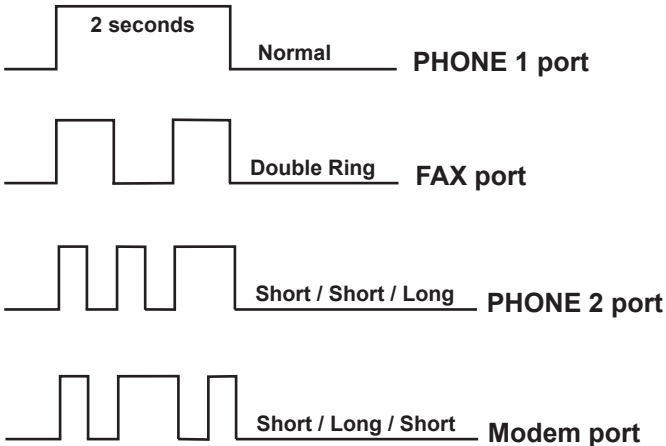

H. LED Operation

IDLE	OFF with a momentary ON every 3.4 seconds
Incoming Ring	Flickers during ring from CO (telephone company) line.
Caller ID Detect	Flicker after first CO ring.
Caller ID Good Checksum	2 Flashes after Caller ID detected flicker.
Caller ID Bad Checksum	4 Flashes after Caller ID detected flicker.
FAXJ-1000 Answered Call	ON
Call Connected to a port	Solid ON
Touch Tone In	OFF while tone is present
Ring Back	Flash

Warranty

IF YOU HAVE A PROBLEM WITH A VIKING PRODUCT, CONTACT VIKING TECHNICAL SUPPORT AT: 715-386-8666

Our Technical Support Department is available for assistance Monday to Friday 8:00am - 5:00pm central time. Before you call, please:

1. Know the model number, the serial number, and what software version you have (see serial label).
2. Have the Product Manual in front of you.
3. It is best if you are on site.

RETURNING PRODUCT FOR REPAIR

The following procedure is for equipment that needs repair:

1. Customer must contact Viking's Technical Support Department at 715-386-8666 to obtain a Return Authorization (RA) number. The customer MUST have a complete description of the problem, with all pertinent information regarding the defect, such as options set, conditions, symptoms, methods to duplicate problem, frequency of failure, etc.
2. Packing: Return equipment in original box or in proper packing so that damage will not occur while in transit. The original product boxes are not designed for shipping - an over-pack box is required to prevent damage in transit. Static sensitive equipment such as a circuit board should be in an anti-static bag, sandwiched between foam and individually boxed. All equipment should be wrapped to avoid packing material lodging in or sticking to the equipment. Include ALL parts of the equipment, C.O.D. or freight collect shipments cannot be accepted. Ship cartons prepaid to:
**VIKING ELECTRONICS
1531 INDUSTRIAL STREET
HUDSON, WI 54016**
3. Return shipping address: Be sure to include your return shipping address inside the box. We cannot ship to a PO Box.
4. RA number on carton: In large printing, write the RA number on the outside of each carton being returned.

RETURNING PRODUCT FOR EXCHANGE

The following procedure is for equipment that has failed out-of-box (within 10 days of purchase):

1. Customer must contact Viking's Technical Support at 715-386-8666 to determine possible causes for the problem. The customer MUST be able to step through recommended tests for diagnosis.
2. If the Technical Support Product Specialist determines that the equipment is defective based on the customer's input and troubleshooting, a Return Authorization (RA) number will be issued. This number is valid for fourteen (14) calendar days from the date of issue.
3. After obtaining the RA number, return the approved equipment to your distributor. Please reference the RA number on the paperwork being shipped back with the unit(s), and also the outside of the shipping box. The original product boxes are not designed for shipping - an over-pack box is required to prevent damage in transit. Once your distributor receives the package, they will replace the product over the counter at no charge. The distributor will then return the product to Viking using the same RA number.
4. The distributor will NOT exchange this product without first obtaining the RA number from you. If you haven't followed the steps listed in 1, 2 and 3, be aware that you will have to pay a restocking charge.

TWO YEAR LIMITED WARRANTY

Viking warrants its products to be free from defects in the workmanship or materials, under normal use and service, for a period of two years from the date of purchase from any authorized Viking distributor. If at any time during the warranty period, the product is deemed defective or malfunctions, return the product to Viking Electronics, Inc., 1531 Industrial Street, Hudson, WI., 54016. Customer must contact Viking's Technical Support Department at 715-386-8666 to obtain a Return Authorization (RA) number.

This warranty does not cover any damage to the product due to lightning, over voltage, under voltage, accident, misuse, abuse, negligence or any damage caused by use of the product by the purchaser or others. This warranty does not cover non-EWP products that have been exposed to wet or corrosive environments. This warranty does not cover stainless steel surfaces that have not been properly maintained.

NO OTHER WARRANTIES, VIKING MAKES NO WARRANTIES RELATING TO ITS PRODUCTS OTHER THAN AS DESCRIBED ABOVE AND DISCLAIMS ANY EXPRESS OR IMPLIED WARRANTIES OR MERCHANTABILITY OR FITNESS FOR ANY PARTICULAR PURPOSE.

EXCLUSION OF CONSEQUENTIAL DAMAGES. VIKING SHALL NOT, UNDER ANY CIRCUMSTANCES, BE LIABLE TO PURCHASER, OR ANY OTHER PARTY, FOR CONSEQUENTIAL, INCIDENTAL, SPECIAL OR EXEMPLARY DAMAGES ARISING OUT OF OR RELATED TO THE SALE OR USE OF THE PRODUCT SOLD HEREUNDER.

EXCLUSIVE REMEDY AND LIMITATION OF LIABILITY. WHETHER IN AN ACTION BASED ON CONTRACT, TORT (INCLUDING NEGLIGENCE OR STRICT LIABILITY) OR ANY OTHER LEGAL THEORY, ANY LIABILITY OF VIKING SHALL BE LIMITED TO REPAIR OR REPLACEMENT OF THE PRODUCT, OR AT VIKING'S OPTION, REFUND OF THE PURCHASE PRICE AS THE EXCLUSIVE REMEDY AND ANY LIABILITY OF VIKING SHALL BE SO LIMITED.

IT IS EXPRESSLY UNDERSTOOD AND AGREED THAT EACH AND EVERY PROVISION OF THIS AGREEMENT WHICH PROVIDES FOR DISCLAIMER OF WARRANTIES, EXCLUSION OF CONSEQUENTIAL DAMAGES, AND EXCLUSIVE REMEDY AND LIMITATION OF LIABILITY, ARE SEVERABLE FROM ANY OTHER PROVISION AND EACH PROVISION IS A SEPARABLE AND INDEPENDENT ELEMENT OF RISK ALLOCATION AND IS INTENDED TO BE ENFORCED AS SUCH.

FCC REQUIREMENTS

This equipment complies with Part 68 of the FCC rules and the requirements adopted by the ACTA. On the side of this equipment is a label that contains, among other information, a product identifier in the format US:AAAEQ##TXXXX. If requested, this number must be provided to the telephone company.

The REN is used to determine the number of devices that may be connected to a telephone line. Excessive REN's on a telephone line may result in the devices not ringing in response to an incoming call. In most but not all areas, the sum of the REN's should not exceed five (5.0). To be certain of the number of devices that may be connected to a line, as determined by the total REN's, contact the local telephone company. For products approved after July 23, 2001, the REN for this product is part of the product identifier that has the format US:AAAEQ##TXXXX. The digits represented by ## are the REN without a decimal point (e.g., 03 is a REN of 0.3). For earlier products, the REN is separately shown on the label.

The plug used to connect this equipment to the premises wiring and telephone network must comply with the applicable FCC Part 68 rules and requirements adopted by the ACTA. If your home has specially wired alarm equipment connected to the telephone line, ensure the installation of this FAXJ-1000 does not disable your alarm equipment. If you have questions about what will qualify alarm equipment, consult your telephone company or a qualified installer.

If the FAXJ-1000 causes harm to the telephone network, the telephone company will notify you in advance that temporary discontinuance of service may be required. But if advance notice isn't practical, the telephone company will notify the customer as soon as possible. Also, you will be advised of your right to file a complaint with the FCC if you believe it is necessary.

The telephone company may make changes in its facilities, equipment, operations, or procedures that could affect the operation of the equipment. If this happens, the telephone company will provide advance notice in order for you to make the necessary modifications to maintain uninterrupted service.

If trouble is experienced with the FAXJ-1000, for repair or warranty information, please contact:

Viking Electronics, Inc., 1531 Industrial Street, Hudson, WI 54016 Phone: (715) 386-8666

If the equipment is causing harm to the telephone network, the telephone company may request that you disconnect the equipment until the problem is resolved.

Connection to Party Line Service is subject to State Tariffs. Contact the state public utility commission, public service commission or corporation commission for information.

WHEN PROGRAMMING EMERGENCY NUMBERS AND (OR) MAKING TEST CALLS TO EMERGENCY NUMBERS:

Remain on the line and briefly explain to the dispatcher the reason for the call. Perform such activities in the off-peak hours, such as early morning or late evenings.

It is recommended that the customer install an AC surge arrester in the AC outlet to which this device is connected. This is to avoid damaging the equipment caused by local lightning strikes and other electrical surges.

PART 15 LIMITATIONS

This equipment has been tested and found to comply with the limits for a Class A digital device, pursuant to Part 15 of the FCC Rules. These limits are designed to provide reasonable protection against harmful interference when the equipment is operated in a commercial environment. This equipment generates, uses, and can radiate radio frequency energy and, if not installed and used in accordance with the instruction manual, may cause harmful interference to radio communications. Operation of this equipment in a residential area is likely to cause harmful interference in which case the user will be required to correct the interference at his own expense.

Product Support: 715-386-8666

Due to the dynamic nature of the product design, the information contained in this document is subject to change without notice. Viking Electronics, and its affiliates and/or subsidiaries assume no responsibility for errors and omissions contained in this information. Revisions of this document or new editions of it may be issued to incorporate such changes.